

NAME:

## CAPTURING THE INFINITE: *From detail to glazes*

Jan Van Eyck, *Arnolfini and his Bride*, 1435, oil on panel



Jan van Eyck, *Man with a Red Turban*

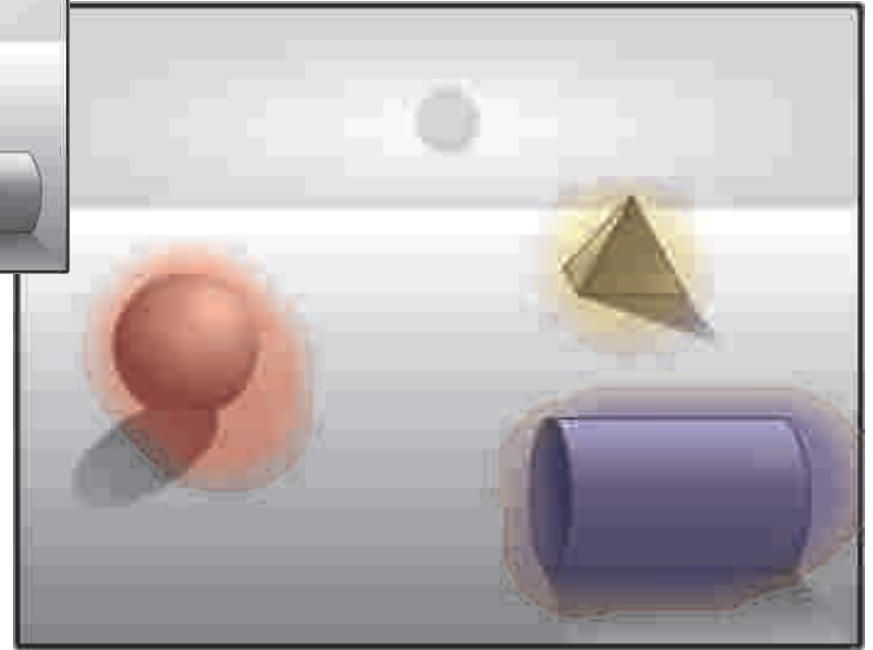
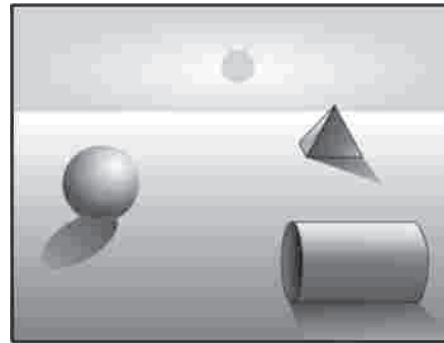

What are the **basic characteristics** of a Northern Renaissance painting?

- 1.
- 2.
- 3.
- 4.
- 5.

**ASSIGNMENT:** On the sheet provided, practice shading techniques using a pencil. **On a separate piece of paper, draw a basic composition, a portrait or genre landscape. Glaze each shape using watercolor.**



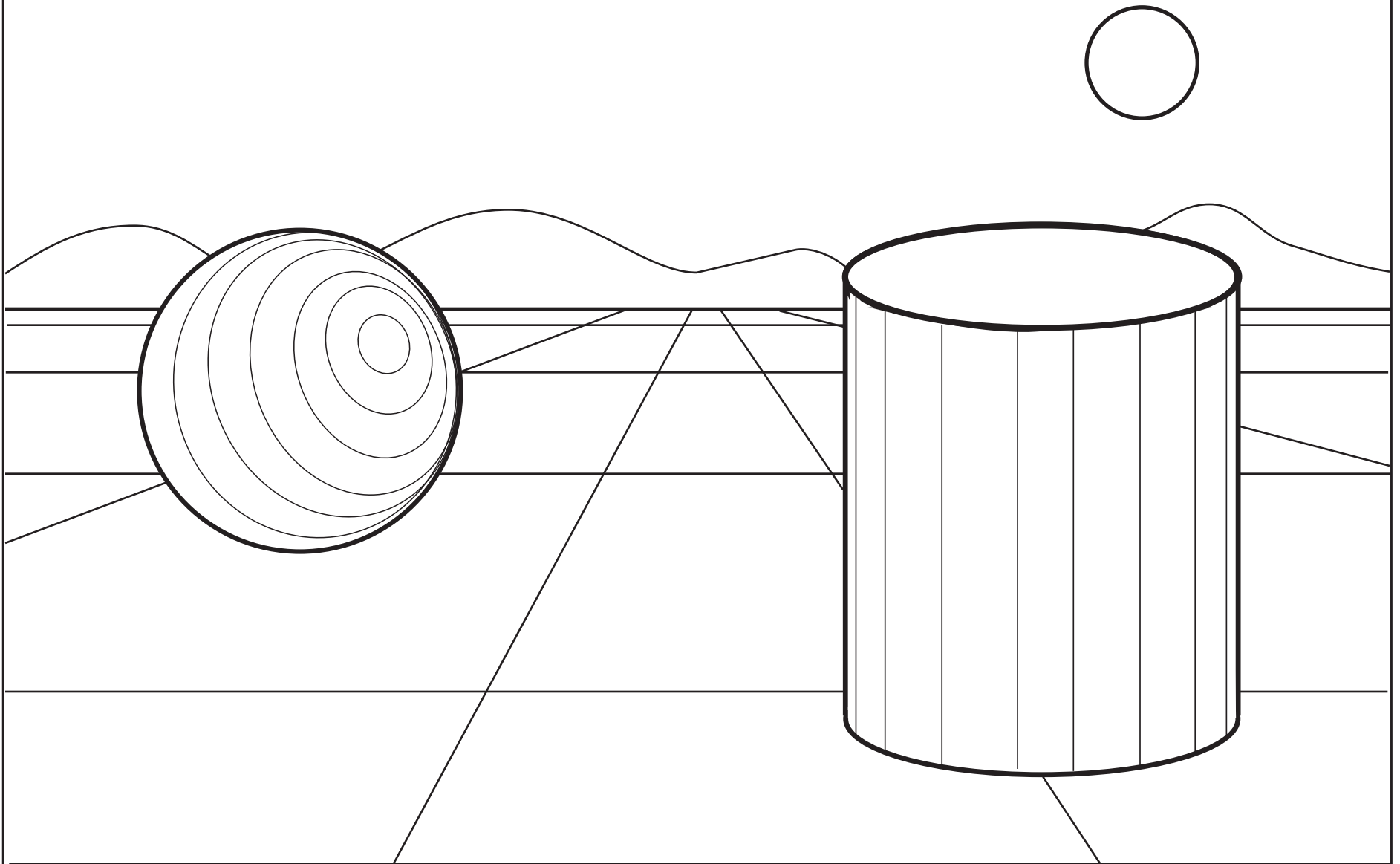

1. Shade using values in pencil.
2. Add thin watercolor over the pencil.
3. Finally, add detail to the objects - pattern, a surface, such as a texture.

**Worksheet**

